

H-Frame Picnic Table BX/PD 450005



Standard Unit Dimensions:

Length: 1500mm
Width: 1500mm
Height: 800mm
Weight: 63kg

Colours/Finishes:



Treated Softwood

The colours shown are a guide only.
Please check a colour chart to see the actual colour.

Product Information

A popular, heavy-duty picnic set that can withstand regular outdoor use. A good-looking yet simply designed piece of outdoor furniture for all ages. The H-Frame Picnic Table has a sturdy base thanks to its precise proportions. Great in parks, school playgrounds, outside pubs, sports and golf clubs.

Features

- Freestanding picnic bench, with option of being fixed if required
- Constructed of heavy duty pressure treated and planed redwood timber
- Timber treated with safe Tanalithe 'E' Hazard Class 4
- Supplied flat packed as standard

Materials Used

- Treated softwood

Options

- Bespoke engravings available

Broxap Limited, Rowhurst Industrial Estate, Chesterton, Newcastle-under-Lyme, Staffordshire, ST5 6BD T: 01782 564411 E: info@broxap.com W: www.broxap.com



H-Frame Picnic Table
BX/PD 450005

Diagram

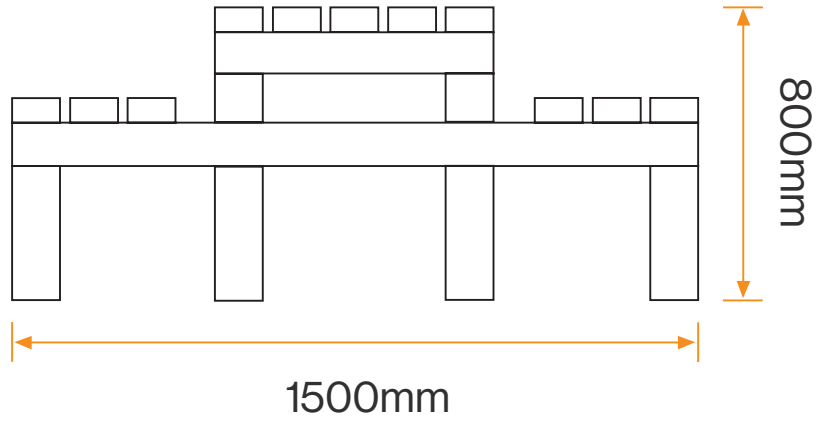

Installation

Free Standing
Picnic Bench



L-Bracket
Surface Fixing

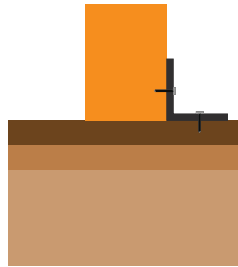

Root/Submerged
Fixing

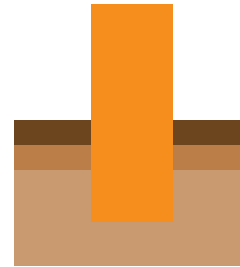

Standard Unit Dimensions:

Length: 1500mm
 Width: 1500mm
 Height: 800mm
 Weight: 63kg

Colours/Finishes:



Treated Softwood

The colours shown are a guide only.
 Please check a colour chart to see the
 actual colour.

Broxap Limited, Rowhurst Industrial Estate, Chesterton, Newcastle-under-Lyme, Staffordshire, ST5 6BD T: 01782 564411 E: info@broxap.com W: www.broxap.com

