

Oldham Standard Planter

BX 1804

broxap[®]
street furniture



Transform your outdoor area with our Oldham Standard Planter.

Features:

- Supplied as standard in grade 250 cast iron
- Wide range of standard RAL/BS colour options
- Promises longevity and resilience against the elements, making it perfect for floral displays
- Potential lifespan of 100 years
- Drainage holes are incorporated into the base, allowing excess water to drain
- Surface mounted planter

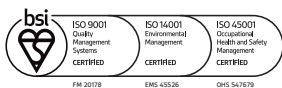

☎ 01782 564411
✉ info@broxap.com
🌐 www.broxap.com

Dimensions

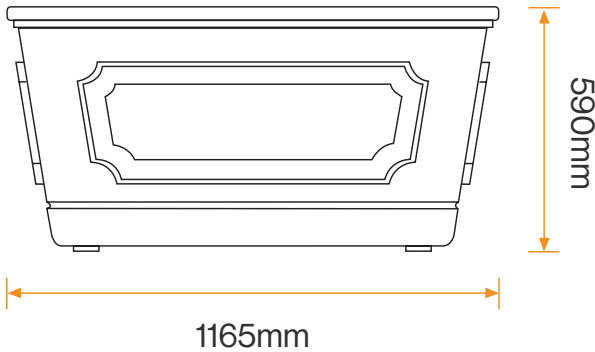

Product Details

Product Name	Oldham Standard Planter
Product Code	BX 1804
Dimensions	1165 x 650 x 590 mm
Weight	285kg
Capacity	363L
Material	Cast Iron
Logo Options	PU logo in standard RAL/BS colour
Additional Options	Painted in any standard RAL/BS colour Gold highlighting
Fixing	Surface mounted



Standard RAL/BS Colours

